

PARTS

C 10FSH

ITEM NO.	CODE NO.	DESCRIPTION	NO. USED	REMARKS
1	305-180	CLUTCH SCREW	1	
2	305-179	CLUTCH SPRING	1	
3	312-488	CLAMP LEVER	1	
4	307-725	BOLT (LEFT HAND) M10	1	
5	315-195	SLEEVE	1	
6	305-190	METAL SPRING (A)	1	
7	965-077	SPECIAL WASHER	1	
8	321-330	SET PIN (A)	1	
9	949-429	BOLT WASHER M4 (10 PCS.)	8	
10	949-215	MACHINE SCREW M4X8 (10 PCS.)	8	
11	320-141	HINGE SHAFT (A)	1	
12	303-409	NYLOCK BOLT M8X25	2	
13	321-370	WISE ASS'Y	1	INCLUD. 14-20
14	308-396	KNOB BOLT M10	1	
15	998-836	KNOB BOLT M6X11	1	
16		SCREW HOLDER	1	
17	319-974	WISE PLATE SET	1	
18	996-722	WASHER	1	
19	996-247	MACHINE SCREW (W/WASHERS) M5X12 (BLACK)	1	
20	321-371	WISE SHAFT	1	
21	302-459	WING BOLT M6X17	1	
22	307-221	BOLT (W/WASHERS) M8X35 (BLACK)	4	
23	321-346	FENCE (B)	1	
24	949-610	BOLT M6X10 (10 PCS.)	1	
25	998-844	HOLDER	1	
26	321-412	TURN TABLE ASS'Y	1	INCLUD. 27
27	321-343	SCALE (B)	1	
28	312-480	SHAFT (B)	1	
29	949-437	BOLT WASHER M12 (10 PCS.)	2	
30	312-481	SPRING	1	
31	321-335	STOPPER (A)	1	
32	321-417	SPRING (E)	1	
33	321-336	PIN COVER	1	
34	998-811	LINER	3	
35	311-144	NYLON NUT M6	1	
36	321-331	PLATE	1	
37	321-386	WARNING LABEL (H)	1	
38	321-385	SUB FENCE (B) ASS'Y	1	INCLUD. 37
39	949-342	FLAT HD. SCREW M6X25 (10 PCS.)	1	
40	319-549	TABLE INSERT	2	
41	949-258	MACHINE SCREW M6X20 (10 PCS.)	6	
42	321-329	INDICATOR	1	
43	321-342	SPACER (A)	1	
44	321-341	SHAFT (A)	1	
45	976-805	SIDE HANDLE	1	
46		CAUTION LABEL (K)	1	
47	321-337	SHAFT (C)	1	
48	875-249	THRUST WASHER	2	
49	987-860	SEAL LOCK HEX. SOCKET SET SCREW M6X6	1	
50	321-339	LEVER SHAFT	1	
51	321-338	LEVER	1	

PARTS

C 10FSH

ITEM NO.	CODE NO.	DESCRIPTION	NO. USED	REMARKS
52	321-340	SPRING (D)	1	
53	321-345	FENCE (A)	1	
* 54A	322-197	BASE ASS'Y	1	INCLUD. 24, 25, 55, 56
* 54A	321-372	BASE ASS'Y	1	INCLUD. 24, 25, 55, 56 FOR USA, CAN
55	312-672	BASE RUBBER	4	
56	315-210	SCALE (A)	1	
* 57	949-616	BOLT M6X25 (10 PCS.)	1	EXCEPT FOR USA, CAN, AUS, NZL
* 58	987-860	SEAL LOCK HEX. SOCKET SET SCREW M6X6	2	EXCEPT FOR USA, CAN, AUS, NZL
* 59	321-552	PIN	2	EXCEPT FOR USA, CAN, AUS, NZL
60		CAUTION LABEL (Q)	1	EXCEPT FOR USA, CAN, AUS, NZL
61	322-617	SUB FENCE (A) ASS'Y	1	INCLUD. 57-60 EXCEPT FOR USA, AUS, NZL
71	996-227	PACKING COVER	2	
72	949-429	BOLT WASHER M4 (10 PCS.)	11	
73	949-215	MACHINE SCREW M4X8 (10 PCS.)	6	
74	321-349	COVER	1	
* 75	322-624	HINGE (A) ASS'Y	1	INCLUD. 105
* 75	322-382	HINGE (A) ASS'Y	1	INCLUD. 105 FOR AUS, NZL
* 75	321-351	HINGE (A) ASS'Y	1	INCLUD. 105 FOR USA, CAN
76	996-276	SLEEVE	1	
77	321-332	SPRING	1	
78	961-554	HEX. SOCKET SET SCREW M8X10	1	
79	302-518	STOPPER PIN ASS'Y	1	INCLUD. 80
80	984-528	O-RING (P-6)	1	
81	319-270	ADJUSTER	1	
82	949-312	WING NUT M8 (10 PCS.)	1	
83	949-633	BOLT M8X50 (10 PCS.)	1	
84	320-141	HINGE SHAFT (A)	1	
85	312-672	BASE RUBBER	1	
86	949-237	MACHINE SCREW M5X12 (10 PCS.)	1	
87	949-454	SPRING WASHER M5 (10 PCS.)	1	
88	998-980	SPACER	1	
* 89	322-199	LINK	1	
* 89	321-368	LINK	1	FOR USA, CAN
90	319-268	PLATE (B)	1	
91	319-267	SPRING	1	
92	305-179	CLUTCH SPRING	2	
93	980-523	NYLON CLIP	1	
94	319-267	SPRING	2	
95	319-541	SEAL LOCK HEX. SOCKET SET SCREW M5X6	2	
96	305-180	CLUTCH SCREW	1	
97	962-614	ADJUSTING WASHER (B) T0.5	1	
98	319-269	HOLDER (B)	1	
* 99	322-618	LASER MARKER	1	
* 99	321-348	LASER MARKER	1	FOR USA, CAN, AUS, NZL
100	319-271	COVER (A)	1	
101	319-272	PLATE (A)	1	
102	949-217	MACHINE SCREW M4X12 (10 PCS.)	5	
103		CAUTION LABEL (J)	1	
* 104	966-803	NYLON CLIP	1	
* 104	948-614	NYLON CLIP	1	FOR AUS, NZL
* 104	948-193	NYLON CLIP	1	FOR USA, CAN

PARTS

C 10FSH

ITEM NO.	CODE NO.	DESCRIPTION	NO. USED	REMARKS	
* 105	322-619	SUPPORT	1		
* 105	321-352	SUPPORT	1	FOR USA, CAN, AUS, NZL	
106	321-347	BALL BUSHING	1		
107	996-226	FELT	2		
108	996-223	BUSHING	2		
109	949-568	LOCK NUT M8 (10 PCS.)	2		
110	974-500	HEX. SOCKET SET SCREW M8X16	2		
111	302-459	WING BOLT M6X17	1		
112	947-859	LOCK SPRING	1		
113	963-174	CLAMP PIECE (B)	1		
114	320-206	CAUTION LABEL (A)	1		
115	321-375	HOLDER (A)	1		
116	949-686	ROLL PIN D6X40 (10 PCS.)	2		
117	321-329	INDICATOR	2		
118	303-409	NYLOCK BOLT M8X25	1		
119	307-956	SEAL LOCK HEX. SOCKET SET SCREW M6X10	2		
* 120	302-503	KNOB BOLT M6X22	1	FOR USA, CAN, AUS, NZL	
121	321-333	GUARD (A)	1		
122	321-394	GUARD HOLDER	1		
* 123	500-439Z	CORD	1	FOR AUS, NZL	
* 123	500-234Z	CORD	1		
* 123	500-241Z	CORD	1	FOR USA, CAN	
* 123	500-435Z	CORD	1	FOR GBR (230V)	
* 123	500-463Z	CORD	1	FOR GBR (110V)	
* 123	500-447Z	CORD	1	FOR SUI	
* 124	960-092	WAVE WASHER	1	FOR USA, CAN	
125	322-210	LINER (A)	1		
* 126	949-332	FLAT HD. SCREW M5X12 (10 PCS.)	2	FOR AUS, NZL	
* 127	322-206	SUB COVER	1	FOR AUS, NZL	
* 128	311-144	NYLON NUT M6	1	EXCEPT FOR USA, CAN, AUS, NZL	
* 129	948-363	GAUGE SPRING	1	EXCEPT FOR USA, CAN, AUS, NZL	
* 130	963-836	SPECIAL BOLT M6	1	EXCEPT FOR USA, CAN, AUS, NZL	
* 131	322-620	VINYL TUBE (A)	1	EXCEPT FOR USA, CAN, AUS, NZL	
* 132	949-455	SPRING WASHER M6 (10 PCS.)	1	EXCEPT FOR USA, CAN, AUS, NZL	
* 133	949-342	FLAT HD. SCREW M6X25 (10 PCS.)	1	EXCEPT FOR USA, CAN, AUS, NZL	
* 134	322-621	BOLT COVER	1	EXCEPT FOR USA, CAN, AUS, NZL	
141	938-051	CORD ARMOR D10.1	1		
142	937-631	CORD CLIP	1		
143	984-750	TAPPING SCREW (W/FLANGE) D4X16	4		
* 144	321-378	SWITCHING POWER SUPPLY	1	FOR 110V-127V	
* 144	322-383	SWITCHING POWER SUPPLY	1	FOR 220V-240V	
* 145	322-384	CONNECTOR (B)	1		
* 145	321-376	CONNECTOR (B)	1	FOR USA, CAN	
* 145	322-450	CONNECTOR (B)	1	FOR GBR (110V)	
146	321-377	INTERNAL WIRE	1		
147	319-349	CORD BUSH	1		
148	321-550	HANDLE (L)	1		
149	305-558	TAPPING SCREW (W/FLANGE) D5X25 (BLACK)	3		
150	321-355	SHEET	1		
* 151	321-354	CONTROLLER 100V-120V	1		
* 151	322-200	CONTROLLER 220V-240V	1		

PARTS

C 10FSH

ITEM NO.	CODE NO.	DESCRIPTION	NO. USED	REMARKS
152	930-804	TERMINAL M4.0 (10 PCS.)	1	
153	321-380	HANDLE (R)	1	
154	301-653	TAPPING SCREW (W/FLANGE) D4X20 (BLACK)	6	
155	880-734	MACHINE SCREW (W/WASHERS) M5X25 (BLACK)	4	
156	319-503	SWITCH (W/COVER)	1	
157	321-383	PULLEY COVER	1	
* 158	959-141	CONNECTOR 50092 (10 PCS.)	2	FOR USA, CAN, AUS, NZL
159	980-063	TERMINAL	1	
* 160	322-451	SWITCH HANDLE (R2)	1	
* 160	321-381	SWITCH HANDLE (R)	1	FOR USA, CAN, AUS, NZL
161	321-356	PULLEY (A)	1	
162	949-426	WASHER M8 (10 PCS.)	2	
163	978-559	SUPER LOCK WASHER	2	
164	949-558	NUT M8 (10 PCS.)	2	
165	620-1VV	BALL BEARING 6201VVCMP2L	1	
166	307-731	COVER	2	
167	949-322	FLAT HD. SCREW M4X10 (10 PCS.)	4	
168	321-357	PULLEY (B)	1	
169	307-736	BELT (170H10)	1	
* 170	998-868	SWITCH (2P PILLAR TYPE) W/O LOCK	1	
* 170	998-839	SWITCH (1P PILLAR TYPE) W/LOCK	1	FOR USA, CAN
* 171	981-373	TUBE (D)	4	
* 171	981-373	TUBE (D)	3	FOR USA, CAN
* 172	322-207	INTERNAL WIRE (A) ASS'Y	1	INCLUD. 159, 171
* 172	321-532	CORD (A) ASS'Y	1	INCLUD. 159, 171 FOR USA, CAN
173	930-703	BRUSH TERMINAL	2	
* 174	340-555C	STATOR ASS'Y 110V	1	INCLUD. 173
* 174	340-539D	STATOR ASS'Y 120V	1	INCLUD. 173
* 174	340-555F	STATOR ASS'Y 230V-240V	1	INCLUD. 173
175	953-174	HEX. HD. TAPPING SCREW D5X55	2	
176	321-399	BALL BEARING 608VVC2NS7L	1	
* 177	360-588U	ARMATURE ASS'Y 110V-120V	1	INCLUD. 176, 219
* 177	360-588E	ARMATURE ASS'Y 230V	1	INCLUD. 176, 219
* 177	360-588F	ARMATURE ASS'Y 240V	1	INCLUD. 176, 219
178	976-441	BEARING LOCK	1	
179	945-161	BRUSH CAP	2	
180	999-043	CARBON BRUSH (1 PAIR)	2	
* 181	960-685	BRUSH HOLDER	2	
* 181	958-900	BRUSH HOLDER	2	FOR USA, CAN
182	938-477	HEX. SOCKET SET SCREW M5X8	2	
* 183	322-208	HOUSING ASS'Y	1	INCLUD. 181, 182
* 183	321-379	HOUSING ASS'Y	1	INCLUD. 181,182 FOR USA, CAN
* 184	996-247	MACHINE SCREW (W/WASHERS) M5X12 (BLACK)	1	EXCEPT FOR NZL
* 185	998-980	SPACER	1	EXCEPT FOR NZL
* 186	996-577	BOLT (W/WASHERS) M6X12 (BLACK)	1	
* 186	998-836	KNOB BOLT M6X11	1	FOR AUS
* 187	318-958	SPINDLE COVER	1	FOR USA, CAN, AUS
* 187	322-622	SPINDLE COVER (A)	1	EXCEPT FOR NZL
188	949-258	MACHINE SCREW M6X20 (10 PCS.)	1	
189	606-ZZM	BALL BEARING 606ZZC2PS2L	1	
190	949-455	SPRING WASHER M6 (10 PCS.)	1	

PARTS

C 10FSH

ITEM NO.	CODE NO.	DESCRIPTION	NO. USED	REMARKS
191	949-425	WASHER M6 (10 PCS.)	1	
192		HITACHI LABEL	1	
193		WARNING LABEL (G)	1	FOR USACAN
194	304-043	MACHINE SCREW (W/WASHERS) M4X10 (BLACK)	1	
195	877-839	SEAL LOCK HEX. SOCKET HD. BOLT M5X10	1	
196	321-384	GEAR CASE	1	
197		WARNING LABEL (M) FOR USA, CAN	1	FOR USA, CAN
197		CAUTION LABEL (M)	1	FOR AUS, NZL
* 198	322-443	TCT SAW BLADE 255MM-D30 HOLE-NT40	1	
* 198		TCT SAW BLADE 262MM-D25.4 HOLE-NT60	1	FOR AUS, NZL
* 198	310-878	TCT SAW BLADE 255MM-D15.88 HOLE-NT40	1	FOR USA, CAN
* 199	308-789	WASHER (D)	2	FOR USA, CAN, AUS, NZL
* 200	322-452	LOWER GUARD	1	
* 200	321-367	SAFETY COVER	1	FOR USA, CAN, AUS, NZL
* 201	322-453	RETURN SPRING (A)	1	
* 201	315-710	RETURN SPRING	1	FOR USA, CAN, AUS, NZL
202	949-241	MACHINE SCREW M5X20 (10 PCS.)	2	
203	949-454	SPRING WASHER M5 (10 PCS.)	2	
204	998-335	BOLT (LEFT HAND) W/WASHER M7X17.5	1	
205	308-787	SPINDLE ASS'Y	1	INCLUD. 206-209
206	600-3DD	BALL BEARING 6003DDCMPS2S	1	
207	308-788	BEARING HOLDER	1	
208	608-VVM	BALL BEARING 608VVC2PS2L	2	
209		PINION	1	
210	931-008	FEATHER KEY 4X4X12	1	
* 211	949-555	NUT M5 (10 PCS.)	1	EXCEPT FOR NZL
212	988-821	LOCK SPRING	1	
213	307-732	STOPPER PIN	1	
214		NAME PLATE	1	
* 215	322-454	DUST GUIDE	1	
* 215	321-364	DUST GUIDE	1	FOR USA, CAN
216	312-492	GUIDE HOLDER	1	
* 217	951-895	LOCK-OFF BUTTON	1	FOR USA, CAN
* 218	322-455	SWITCH HANDLE (L2)	1	
* 218	322-209	SWITCH HANDLE (L)	1	FOR AUS, NZL
* 218	321-382	SWITCH HANDLE (L)	1	FOR USA, CAN
219	321-398	BALL BEARING 6201VVCMNS7S	1	
* 220	949-432	BOLT WASHER M6 (10 PCS.)	1	FOR AUS
* 221	976-819	COLLAR (B) FOR D25.4 HOLE	1	FOR AUS, NZL
* 222	322-456	LEVER	1	EXCEPT FOR USA, CAN, AUS, NZL
* 223	302-757	SPACER	2	EXCEPT FOR USA, CAN, AUS, NZL
* 224	935-196	MACHINE SCREW (W/WASHERS) M4X12 (BLACK)	3	EXCEPT FOR USA, CAN, AUS, NZL
* 225	322-457	LEVER SPRING	1	EXCEPT FOR USA, CAN, AUS, NZL
* 226	322-458	PLATE (C)	1	EXCEPT FOR USA, CAN, AUS, NZL
* 227	306-371	TAPPING SCREW (W/FLANGE) D3X10 (BLACK)	2	EXCEPT FOR USA, CAN, AUS, NZL
* 228	322-459	WASHER (A)	1	EXCEPT FOR USA, CAN, AUS, NZL
* 229	318-962	WASHER (B)	1	EXCEPT FOR USA, CAN, AUS, NZL
* 230	958-308Z	PILLAR TERMINAL (A)	1	EXCEPT FOR USA, CAN, AUS, NZL
* 231	305-171	SPACER	1	EXCEPT FOR USA, CAN, AUS, NZL
* 232	304-043	MACHINE SCREW (W/WASHERS) M4X10 (BLACK)	1	EXCEPT FOR USA, CAN, AUS, NZL
* 233	322-623	SUB COVER (A)	1	EXCEPT FOR USA, CAN, AUS, NZL

STANDARD ACCESSORIES

C 10FSH

ITEM NO.	CODE NO.	DESCRIPTION	NO. USED	REMARKS
501	940-543	BOX WRENCH 10MM	1	
502	998-845	DUST BAG	1	
* 503	974-663Z	COLLAR (A) FOR D30 HOLE	1	FOR AUS

OPTIONAL ACCESSORIES

ITEM NO.	CODE NO.	DESCRIPTION	NO. USED	REMARKS
601	321-434	CROWN MOLDING VISE ASS'Y	1	INCLUD. 602, 618
602	321-388	VISE (B) ASS'Y	1	INCLUD. 603-608
603	321-551	KNOB BOLT M10X54	1	
604	998-836	KNOB BOLT M6X11	1	
605		SCREW HOLDER (B)	1	
606	306-985	WASHER (H)	1	
607	964-851	BASE RUBBER	1	
608	304-043	MACHINE SCREW (W/WASHERS) M4X10 (BLACK)	1	
* 609	960-017	KNOB BOLT M6X32	1	FOR USA, CAN, AUS, NZL
* 610	987-860	SEAL LOCK HEX. SOCKET SET SCREW M6X6	2	FOR USA, CAN, AUS, NZL
* 611	321-552	PIN	2	FOR USA, CAN, AUS, NZL
612		WARNING LABEL (L) FOR USA, CAN, AUS, NZL	1	
* 613	321-387	SUB FENCE (A) ASS'Y	1	INCLUD. 609-612 FOR USA, CAN, AUS, NZL
614	960-017	KNOB BOLT M6X32	1	
615	301-806	WING BOLT M6X15	1	
616		CROWN MOLDING STOPPER (L)	1	
617	321-390	CROWN MOLDING STOPPER HOLDER	1	
618	321-374	CROWN MOLDING STOPPER (L) ASS'Y	1	INCLUD. 614-617
619	974-561	STOPPER	1	
620	949-404	WING BOLT M6X20 (10 PCS.)	1	
621	321-390	CROWN MOLDING STOPPER HOLDER	1	
622		CROWN MOLDING STOPPER (R)	1	
623	301-806	WING BOLT M6X15	1	
624	321-373	CROWN MOLDING STOPPER (R) ASS'Y	1	INCLUD. 614, 621-623
625	321-549	HOLDER	2	
626	949-313	WING NUT M6 (10 PCS.)	2	
627	949-556	NUT M6 (10 PCS.)	2	
628	967-329	WASHER (H)	4	
629	996-261	VISE PLATE	2	
630	996-283	HIGH TENSION BOLT M6X65	2	
631	321-553	GUIDE ASS'Y	1	INCLUD. 614, 619, 620, 625-630
* 632	322-444	TCT SAW BLADE 255MM-D30 HOLE-NT72	1	
* 632	307-713	TCT SAW BLADE 255MM-D25.4 HOLE-NT72	1	FOR AUS, NZL

ELECTRIC TOOL PARTS LIST

SLIDE COMPOUND SAW Model C 10FSB

2004 • 2 • 13

(E2)

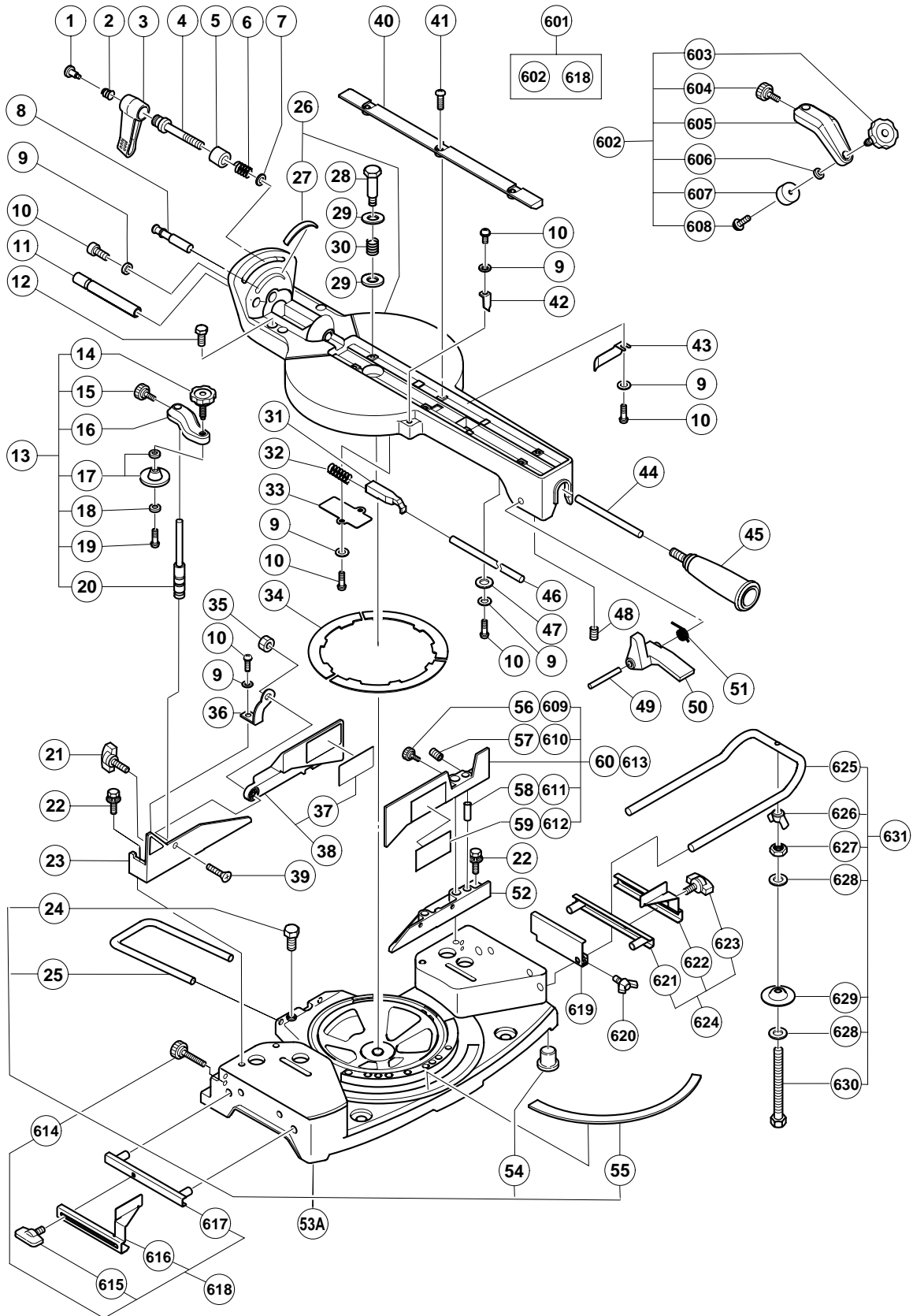

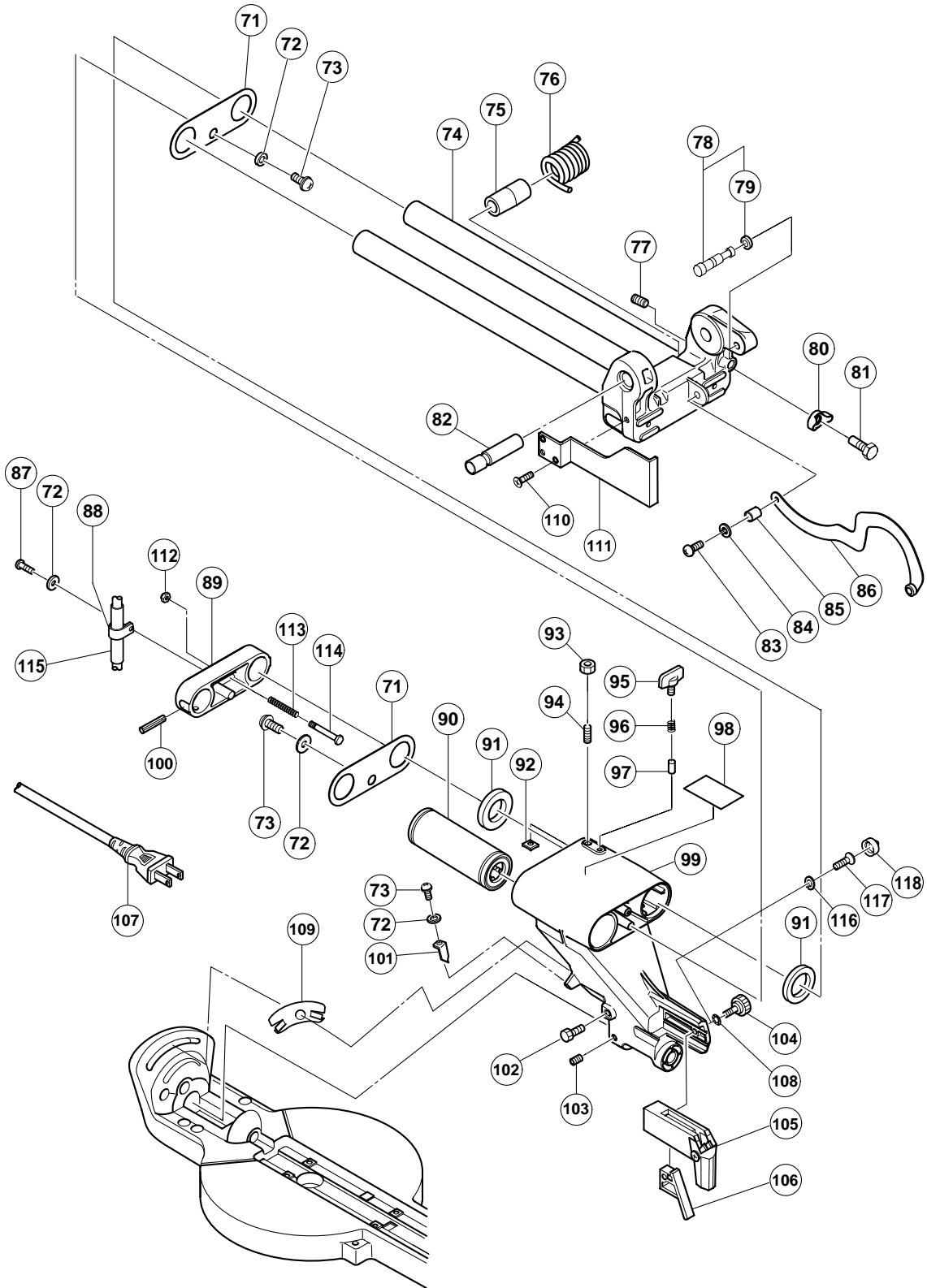

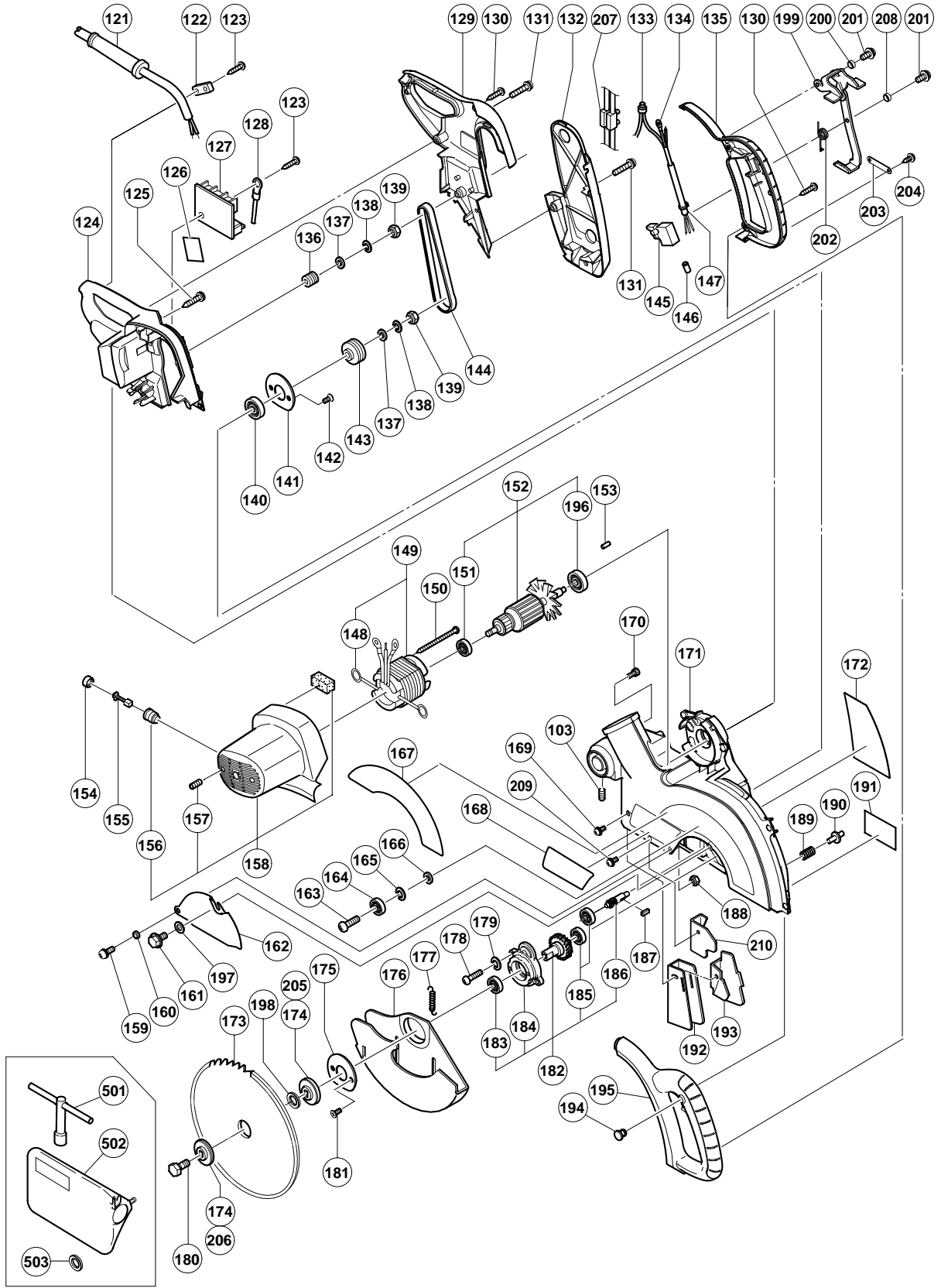

PARTS

C 10FSB

ITEM NO.	CODE NO.	DESCRIPTION	NO. USED	REMARKS
1	305-180	CLUTCH SCREW	1	
2	305-179	CLUTCH SPRING	1	
3	312-488	CLAMP LEVER	1	
4	307-725	BOLT (LEFT HAND) M10	1	
5	315-195	SLEEVE	1	
6	305-190	METAL SPRING (A)	1	
7	965-077	SPECIAL WASHER	1	
8	321-330	SET PIN (A)	1	
9	949-429	BOLT WASHER M4 (10 PCS.)	8	
10	949-215	MACHINE SCREW M4X8 (10 PCS.)	8	
11	320-141	HINGE SHAFT (A)	1	
12	303-409	NYLOCK BOLT M8X25	2	
13	321-370	WISE ASS'Y	1	INCLUD. 14-20
14	308-396	KNOB BOLT M10	1	
15	998-836	KNOB BOLT M6X11	1	
16		SCREW HOLDER	1	
17	319-974	WISE PLATE SET	1	
18	996-722	WASHER	1	
19	996-247	MACHINE SCREW (W/WASHERS) M5X12 (BLACK)	1	
20	321-371	WISE SHAFT	1	
21	302-459	WING BOLT M6X17	1	
22	307-221	BOLT (W/WASHERS) M8X35 (BLACK)	4	
23	321-346	FENCE (B)	1	
24	949-610	BOLT M6X10 (10 PCS.)	1	
25	998-844	HOLDER	1	
26	321-412	TURN TABLE ASS'Y	1	INCLUD. 27
27	321-343	SCALE (B)	1	
28	312-480	SHAFT (B)	1	
29	949-437	BOLT WASHER M12 (10 PCS.)	2	
30	312-481	SPRING	1	
31	321-335	STOPPER (A)	1	
32	321-417	SPRING (E)	1	
33	321-336	PIN COVER	1	
34	998-811	LINER	3	
35	311-144	NYLON NUT M6	1	
36	321-331	PLATE	1	
37	321-386	WARNING LABEL (H)	1	
38	321-385	SUB FENCE (B) ASS'Y	1	INCLUD. 37
39	949-342	FLAT HD. SCREW M6X25 (10 PCS.)	1	
40	998-818	TABLE INSERT	2	
41	949-258	MACHINE SCREW M6X20 (10 PCS.)	6	
42	321-329	INDICATOR	1	
43	321-342	SPACER (A)	1	
44	321-341	SHAFT (A)	1	
45	976-805	SIDE HANDLE	1	
46	321-337	SHAFT (C)	1	
47	875-249	THRUST WASHER	2	
48	987-860	SEAL LOCK HEX. SOCKET SET SCREW M6X6	1	
49	321-339	LEVER SHAFT	1	
50	321-338	LEVER	1	
51	321-340	SPRING (D)	1	

PARTS

ITEM NO.	CODE NO.	DESCRIPTION	NO. USED	REMARKS
52	321-345	FENCE (A)	1	
* 53A	322-197	BASE ASS'Y	1	INCLUD. 24, 25, 54, 55
* 53A	321-372	BASE ASS'Y	1	INCLUD. 24, 25, 54, 55 FOR USA, CAN
54	312-672	BASE RUBBER	4	
55	315-210	SCALE (A)	1	
* 56	949-616	BOLT M6X25 (10 PCS.)	1	EXCEPT FOR USA, CAN, AUS, NZL
* 57	987-860	SEAL LOCK HEX. SOCKET SET SCREW M6X6	2	EXCEPT FOR USA, CAN, AUS, NZL
* 58	321-552	PIN	2	EXCEPT FOR USA, CAN, AUS, NZL
59		CAUTION LABEL (Q)	1	EXCEPT FOR USA, CAN, AUS, NZL
* 60	322-617	SUB FENCE (A) ASS'Y	1	INCLUD. 56-59 EXCEPT FOR USA, CAN, AUS, NZL
71	996-227	PACKING COVER	2	
72	949-429	BOLT WASHER M4 (10 PCS.)	5	
73	949-215	MACHINE SCREW M4X8 (10 PCS.)	4	
* 74	322-198	HINGE (B) ASS'Y	1	INCLUD. 89 FOR AUS, NZL
* 74	322-653	HINGE (B) ASS'Y	1	INCLUD. 89
* 74	321-391	HINGE (B) ASS'Y	1	INCLUD. 89 FOR USA, CAN
75	996-276	SLEEVE	1	
76	321-332	SPRING	1	
77	961-554	HEX. SOCKET SET SCREW M8X10	1	
78	302-518	STOPPER PIN ASS'Y	1	INCLUD. 79
79	984-528	O-RING (P-6)	1	
80	949-312	WING NUT M8 (10 PCS.)	1	
81	949-633	BOLT M8X50 (10 PCS.)	1	
82	320-141	HINGE SHAFT (A)	1	
83	949-237	MACHINE SCREW M5X12 (10 PCS.)	1	
84	949-454	SPRING WASHER M5 (10 PCS.)	1	
85	998-980	SPACER	1	
* 86	322-199	LINK	1	
* 86	321-368	LINK	1	FOR USA, CAN
87	949-217	MACHINE SCREW M4X12 (10 PCS.)	1	
* 88	948-614	NYLON CLIP	1	FOR AUS, NZL
* 88	966-803	NYLON CLIP	1	
* 88	948-193	NYLON CLIP	1	FOR USA, CAN
* 89	322-619	SUPPORT	1	
* 89	321-352	SUPPORT	1	FOR USA, CAN, AUS, NZL
90	321-347	BALL BUSHING	1	
91	996-226	FELT	2	
92	996-223	BUSHING	2	
93	949-568	LOCK NUT M8 (10 PCS.)	2	
94	974-500	HEX. SOCKET SET SCREW M8X16	2	
95	302-459	WING BOLT M6X17	1	
96	947-859	LOCK SPRING	1	
97	963-174	CLAMP PIECE (B)	1	
98	320-206	CAUTION LABEL (A)	1	
99	321-375	HOLDER (A)	1	
100	949-686	ROLL PIN D6X40 (10 PCS.)	2	
101	321-329	INDICATOR	2	
102	303-409	NYLOCK BOLT M8X25	1	
103	307-956	SEAL LOCK HEX. SOCKET SET SCREW M6X10	2	
* 104	302-503	KNOB BOLT M6X22	1	FOR USA, CAN, AUS, NZL
105	321-333	GUARD (A)	1	

PARTS

C 10FSB

ITEM NO.	CODE NO.	DESCRIPTION	NO. USED	REMARKS
106	321-394	GUARD HOLDER	1	
* 107	500-234Z	CORD	1	
* 107	500-241Z	CORD	1	FOR USA, CAN
* 107	500-435Z	CORD	1	FOR GBR (230V)
* 107	500-463Z	CORD	1	FOR GBR (110V)
* 107	500-447Z	CORD	1	FOR SUI
* 107	500-439Z	CORD	1	FOR AUS, NZL
* 108	960-092	WAVE WASHER	1	FOR USA, CAN
109	322-210	LINER (A)	1	
* 110	949-332	FLAT HD. SCREW M5X12 (10 PCS.)	2	FOR AUS, NZL
* 111	322-206	SUB COVER	1	FOR AUS, NZL
* 112	311-144	NYLON NUT M6	1	EXCEPT FOR USA, CAN, AUS, NZL
* 113	948-363	GAUGE SPRING	1	EXCEPT FOR USA, CAN, AUS, NZL
* 114	963-836	SPECIAL BOLT M6	1	EXCEPT FOR USA, CAN, AUS, NZL
* 115	322-620	VINYL TUBE (A)	1	EXCEPT FOR USA, CAN, AUS, NZL
* 116	949-455	SPRING WASHER M6 (10 PCS.)	1	EXCEPT FOR USA, CAN, AUS, NZL
* 117	949-342	FLAT HD. SCREW M6X25 (10 PCS.)	1	EXCEPT FOR USA, CAN, AUS, NZL
* 118	322-621	BOLT COVER	1	EXCEPT FOR USA, CAN, AUS, NZL
121	938-051	CORD ARMOR D10.1	1	
122	937-631	CORD CLIP	1	
123	984-750	TAPPING SCREW (W/FLANGE) D4X16	3	
124	321-392	HANDLE (L)	1	
125	305-558	TAPPING SCREW (W/FLANGE) D5X25 (BLACK)	3	
126	321-355	SHEET	1	
* 127	321-354	CONTROLLER 100V-120V	1	
* 127	322-200	CONTROLLER 220V-240V	1	
128	930-804	TERMINAL M4.0 (10 PCS.)	1	
129	321-393	HANDLE (R)	1	
130	301-653	TAPPING SCREW (W/FLANGE) D4X20 (BLACK)	6	
131	880-734	MACHINE SCREW (W/WASHERS) M5X25 (BLACK)	4	
132	321-383	PULLEY COVER	1	
133	959-141	CONNECTOR 50092 (10 PCS.)	2	FOR USA, CAN, AUS, NZL
* 134	980-063	TERMINAL	1	
* 135	322-451	SWITCH HANDLE (R2)	1	
* 135	321-381	SWITCH HANDLE (R)	1	FOR USA, CAN, AUS, NZL
136	321-356	PULLEY (A)	1	
137	949-426	WASHER M8 (10 PCS.)	2	
138	978-559	SUPER LOCK WASHER	2	
139	949-558	NUT M8 (10 PCS.)	2	
140	620-1VV	BALL BEARING 6201VVCMP2L	1	
141	307-731	COVER	1	
142	949-322	FLAT HD. SCREW M4X10 (10 PCS.)	2	
143	321-357	PULLEY (B)	1	
144	307-736	BELT (170H10)	1	
* 145	998-868	SWITCH (2P PILLAR TYPE) W/O LOCK	1	
* 145	998-839	SWITCH (1P PILLAR TYPE) W/LOCK	1	FOR USA, CAN
* 146	981-373	TUBE (D)	4	
* 146	981-373	TUBE (D)	3	FOR USA, CAN
* 147	322-207	INTERNAL WIRE (A) ASS'Y	1	INCLUD. 134, 146
* 147	321-532	CORD (A) ASS'Y	1	INCLUD. 134, 146 FOR USA, CAN
* 148	930-703	BRUSH TERMINAL	2	INCLUD. 134, 146 FOR USA, CAN

PARTS

C 10FSB

ITEM NO.	CODE NO.	DESCRIPTION	NO. USED	REMARKS	
* 149	340-555C	STATOR ASS'Y 110V	1	INCLUD. 148	
* 149	340-539D	STATOR ASS'Y 120V	1	INCLUD. 148	
* 149	340-555F	STATOR ASS'Y 230V-240V	1	INCLUD. 148	
	150	953-174	HEX. HD. TAPPING SCREW D5X55	2	
	151	321-399	BALL BEARING 608VVC2NS7L	1	
* 152	360-588U	ARMATURE ASS'Y 110V-120V	1	INCLUD. 151, 196	
* 152	360-588E	ARMATURE ASS'Y 230V	1	INCLUD. 151, 196	
* 152	360-588F	ARMATURE ASS'Y 240V	1	INCLUD. 151, 196	
	153	976-441	BEARING LOCK	1	
	154	945-161	BRUSH CAP	2	
	155	999-043	CARBON BRUSH (1 PAIR)	2	
* 156	960-685	BRUSH HOLDER	2		
* 156	958-900	BRUSH HOLDER	2	FOR USA, CAN	
	157	938-477	HEX. SOCKET SET SCREW M5X8	2	
* 158	322-208	HOUSING ASS'Y	1	INCLUD. 156, 157	
* 158	321-379	HOUSING ASS'Y	1	INCLUD. 156, 157 FOR USA, CAN	
* 159	996-247	MACHINE SCREW (W/WASHERS) M5X12 (BLACK)	1	EXCEPT FOR NZL	
* 160	998-980	SPACER	1	EXCEPT FOR NZL	
* 161	996-577	BOLT (W/WASHERS) M6X12 (BLACK)	1		
* 161	998-836	KNOB BOLT M6X11	1	FOR AUS	
* 162	318-958	SPINDLE COVER	1	FOR USA, CAN, AUS	
* 162	322-622	SPINDLE COVER (A)	1	EXCEPT FOR NZL	
	163	949-258	MACHINE SCREW M6X20 (10 PCS.)	1	
	164	606-ZZM	BALL BEARING 606ZZC2PS2L	1	
	165	949-455	SPRING WASHER M6 (10 PCS.)	1	
	166	949-425	WASHER M6 (10 PCS.)	1	
	167		HITACHI LABEL	1	
	168		WARNING LABEL (G)	1	FOR USA, CAN
	169	304-043	MACHINE SCREW (W/WASHERS) M4X10 (BLACK)	1	
	170	877-839	SEAL LOCK HEX. SOCKET HD. BOLT M5X10	1	
	171	321-384	GEAR CASE	1	
	172		WARNING LABEL (G)	1	FOR USA, CAN
* 173	322-443	TCT SAW BLADE 255MM-D30 HOLE-NT40	1		
* 173		TCT SAW BLADE 262MM-D25.4 HOLE-NT60	1	FOR AUS, NZL	
* 173	310-878	TCT SAW BLADE 255MM-D15.88 HOLE-NT40	1	FOR USA, CAN	
* 174	308-789	WASHER (D)	2	FOR USA, CAN, AUS, NZL	
	175	307-731	COVER	1	
* 176	322-452	LOWER GUARD	1		
* 176	321-367	SAFETY COVER	1	FOR USA, CAN, AUS, NZL	
* 177	322-453	RETURN SPRING (A)	1		
* 177	315-710	RETURN SPRING	1	FOR USA, CAN, AUS, NZL	
	178	949-241	MACHINE SCREW M5X20 (10 PCS.)	2	
	179	949-454	SPRING WASHER M5 (10 PCS.)	2	
	180	998-335	BOLT (LEFT HAND) W/WASHER M7X17.5	1	
	181	949-322	FLAT HD. SCREW M4X10 (10 PCS.)	2	
	182	308-787	SPINDLE ASS'Y	1	INCLUD. 183-186
	183	600-3DD	BALL BEARING 6003DDCMPS2S	1	
	184	308-788	BEARING HOLDER	1	
	185	608-VVM	BALL BEARING 608VVC2PS2L	2	
	186		PINION	1	
	187	931-008	FEATHER KEY 4X4X12	1	

STANDARD ACCESSORIES

C 10FSB

ITEM NO.	CODE NO.	DESCRIPTION	NO. USED	REMARKS
501	940-543	BOX WRENCH 10MM	1	
502	998-845	DUST BAG	1	
* 503	974-663Z	COLLAR (A) FOR D30 HOLE	1	FOR AUS

OPTIONAL ACCESSORIES

ITEM NO.	CODE NO.	DESCRIPTION	NO. USED	REMARKS
601	321-434	CROWN MOLDING VISE ASS'Y	1	INCLUD. 602, 618
602	321-388	VISE (B) ASS'Y	1	INCLUD. 603-608
603	321-551	KNOB BOLT M10X54	1	
604	998-836	KNOB BOLT M6X11	1	
605		SCREW HOLDER (B)	1	
606	306-985	WASHER (H)	1	
607	964-851	BASE RUBBER	1	
608	304-043	MACHINE SCREW (W/WASHERS) M4X10 (BLACK)	1	
* 609	960-017	KNOB BOLT M6X32	1	FOR USA, CAN, AUS, NZL
* 610	987-860	SEAL LOCK HEX. SOCKET SET SCREW M6X6	2	FOR USA, CAN, AUS, NZL
* 611	321-552	PIN	2	FOR USA, CAN, AUS, NZL
612		WARNING LABEL (L) FOR USA, CAN, AUS, NZL	1	
* 613	321-387	SUB FENCE (A) ASS'Y	1	INCLUD. 609-612 FOR USA, CAN, AUS, NZL
614	960-017	KNOB BOLT M6X32	1	
615	301-806	WING BOLT M6X15	1	
616		CROWN MOLDING STOPPER (L)	1	
617	321-390	CROWN MOLDING STOPPER HOLDER	1	
618	321-374	CROWN MOLDING STOPPER (L) ASS'Y	1	INCLUD. 614-617
619	974-561	STOPPER	1	
620	949-404	WING BOLT M6X20 (10 PCS.)	1	
621	321-390	CROWN MOLDING STOPPER HOLDER	1	
622		CROWN HOLDING STOPPER (R)	1	
623	301-806	WING BOLT M6X15	1	
624	321-373	CROWN MOLDING STOPPER (R) ASS'Y	1	INCLUD. 614,621-623
625	321-549	HOLDER	2	
626	949-313	WING NUT M6 (10 PCS.)	2	
627	949-556	NUT M6 (10 PCS.)	2	
628	967-329	WASHER (H)	4	
629	996-261	VISE PLATE	2	
630	996-283	HIGH TENSION BOLT M6X65	2	
631	321-553	GUIDE ASS'Y	1	INCLUD. 614, 619, 620, 625-630
* 632	322-444	TCT SAW BLADE 255MM-D30 HOLE-NT72	1	
* 632	307-713	TCT SAW BLADE 255MM-D25.4 HOLE-NT72	1	FOR AUS, NZL